

CD100MV Dri-Prime® Pumps

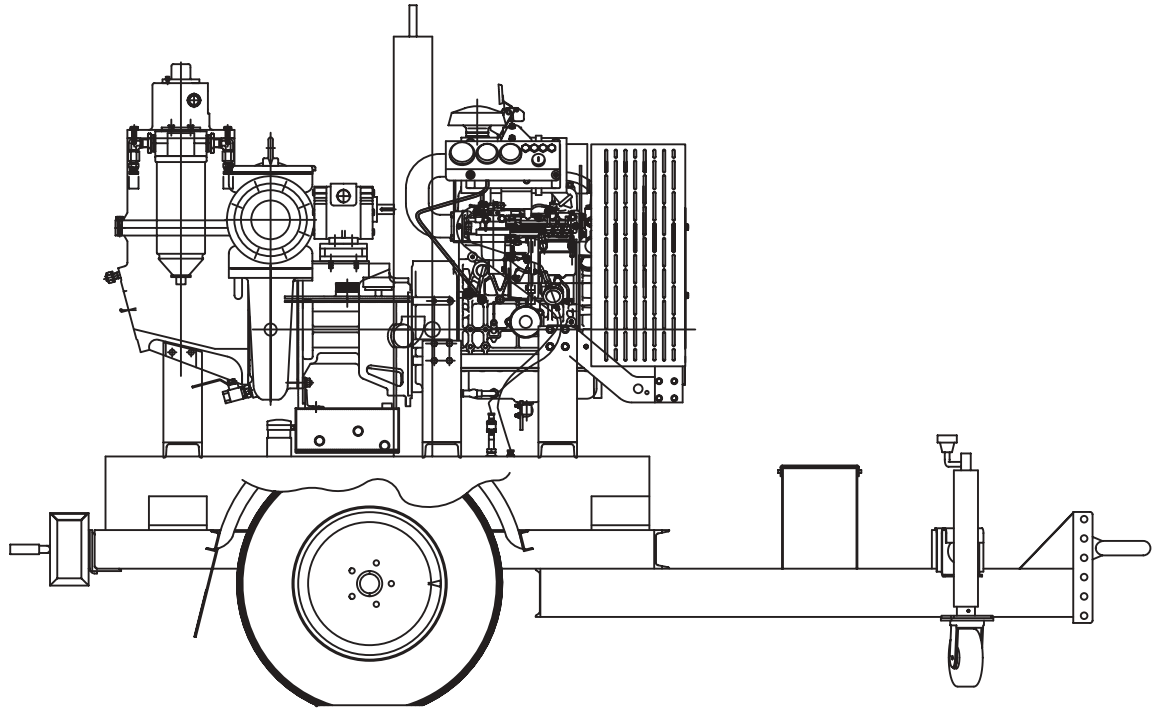

The CD100MV is a portable wellpoint pump designed for a wide range of on-site dewatering applications. Based on the popular, industry-standard CD100M Dri-Prime® Pump, the CD100MV offers flow capabilities to 750 gallons per minute (47 liters per second), total dynamic heads to 115 feet (35 meters) and solids handling to 2 inch (50mm) in diameter along with convenient automatic self-priming and indefinite dry running capabilities. The CD100MV consists of a centrifugal, single stage end suction pump, a high volume, belt driven vacuum pump, and a single action, float actuated air/water separation tank. A reliable and efficient Yanmar 3TNV88 or Caterpillar 3014NA diesel engine powers both pump and vacuum components. An integral overnight running fuel tank within the trailer provides continuous wellpoint operation. Additionally, the CD100MV operates with the full line of Godwin Wellpoint pipe and fittings including Quick Disconnect header pipes, riser pipes and adaptors, swing arm assemblies, and stainless steel, self-jetting wellpoint screens.

Features

- Flow rates to 750 gpm (47 l/sec.). Total heads to 115 feet (35M).
- Handles raw sewage, slurries, and liquids with solids up to 2" (50mm) in diameter.
- Dry running, high pressure, oil bath mechanical seal with abrasion resistant solid Silicon Carbide faces – capable of long term dry running encountered in wellpoint dewatering.
- Single action float and separation tank operation protects vacuum system in high water level conditions.
- Full line of Godwin Wellpoint pipe and fittings available
- Convenient compact skid or portable trailer mounting available.
- Standard engine – Yanmar 3TNV88 or Caterpillar 3014NA. Available with a variety of engines, including Hatz and Deutz.
- A variety of silenced units are available.

CD100MV Performance Curve

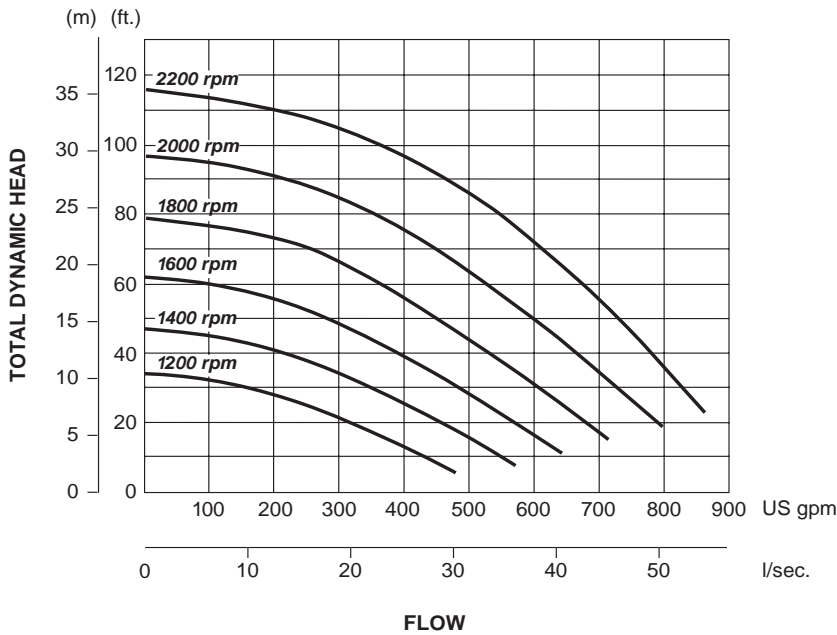

CD100MV Performance Table

Diesel Set — Yanmar 3TNV88, 24 hp (18 kw) @ 2200 rpm
 Caterpillar 3014NA, 28 hp (21 kw) @ 2200 rpm
Impeller Diameter — 8-5/8 in. (220 mm)

Total Suction Head - Feet	Total Delivery Head — Feet				
	10	20	30	40	50
	Output — GPM				
10	720	710	700	695	690
15	615	580	530	500	450
20	510	490	475	430	375
25	450	440	400	390	350

Performance data listed in table and curves are based on water tests at sea level and 68° F (20° C). Larger diameter pipes may be required for maximum flows.

Dimensions

CD100M — Yanmar 3TNV88, GP60 Highway Trailer
 Weight: 1734 lbs. (788 kg.)

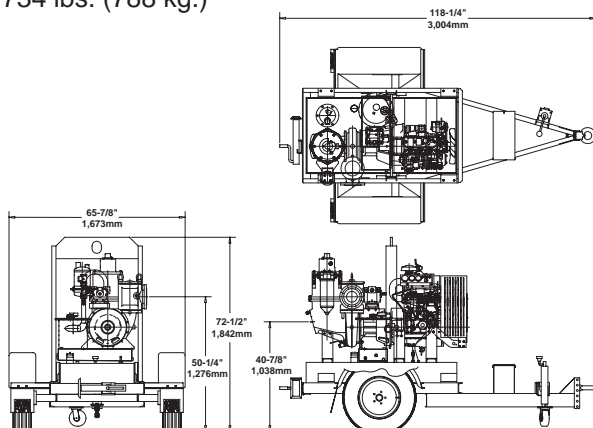

Dimensions are approximate. Please consult factory for exact dimensions.

Specifications

- Maximum Operating Speed:**
2200 rpm
- Vacuum Pump Range:**
25 cfm (.73 m³/min)
- Fuel Tank Capacity:**
60 gallons (227 liters)
- Fuel Consumption** (full load, max. speed):
Yanmar: 1.21 gph (4.58 lph) @ 2200 rpm
CAT: 1.67 gph (6.32 lph) @ 2200 rpm
- Pipe Connections:**
4" (100mm) ASA 150#
- Solids Handling:**
2" (50mm) diameter

Materials

- Pump Casing, Suction Cover, Separation Tank and Wearplates:**
Close grained cast iron
- Impeller:**
Cast chromium steel hardened to minimum Brinell 341 HB
- Shaft Sleeve and Shaft:**
1-1/2% nickel/chromium steel
- Mechanical Seal Faces:**
Solid Silicon Carbide



One Floodgate Road, Bridgeport, NJ 08014, USA
 (856) 467-3636 • Fax: (856) 467-4841
 Quenington, Cirencester, Glos., GL7 5BX, UK
 +44 (0)1285 750271 • Fax: +44 (0)1285 750352

E-mail: sales@godwinpumps.com
 www.godwinpumps.com

BRANCH LOCATIONS:

- Connecticut • Pennsylvania • New York • Ohio
- Illinois • Maryland • Virginia • West Virginia
- North Carolina • South Carolina • Georgia
- Florida • Texas • Montana • California • Washington

Dri-Prime® is a registered trademark of Godwin Pumps of America, Inc. Specifications and illustrations are subject to revision without notice. © Copyright 2002-2005 Godwin Pumps of America, Inc.