

HL110M Dri-Prime® Pumps

The Godwin Dri-Prime 4" x 3" (100 mm x 80 mm) HL110M pump is a heavy-duty, fully automatic self-priming pump specifically offered for pumping under extreme high pressure discharge conditions or high discharge lift applications. The HL110M offers flow rates up to 500 GPM (115 m³/h), total dynamic heads up to 615' (185 m) and solids handling up to 0.787" (20 mm) in diameter. Like all Godwin pumps, the HL110M pump includes the Dri-Prime air ejector priming system for fully automatic priming up to 28' (8.5 m) of static suction lift.

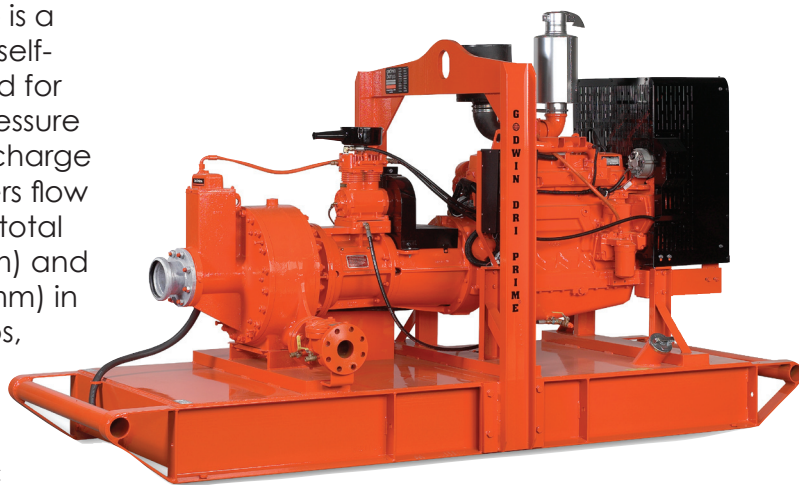

Features

- Fully automatic priming from dry to 28' (8.5 m) of suction lift.
- Handles liquids with solids up to 0.787" (20 mm) in diameter.
- Continuously operated Venturi air ejector priming system operated by an air compressor, requires no form of periodic adjustment or operator intervention.
- Dual, high pressure, dry running solid silicon carbide inboard and carbon/stainless outboard mechanical seal with self-contained oil-bath cooling.
- Mounted to a structural steel skid with integrated 175 gal. (662 l) fuel tank and lifting bail. Optional road going trailer also available.
- Standard engine - JD6068T. Other engines and electric motor also available upon request.

Specifications

Suction	4" (100 mm/125#)
Discharge	3" (80 mm/250#)
Max. Capacity	500 GPM (115 m ³ /h)
Max. Head	615' (185 m)
Max. Solids Handling	0.78" (20 mm)
Impeller Type	Fully open
# of Blades	3
Max. Impeller Diam.	20" (465 mm)
Max. Op. Temp.	+212° F (100° C)
Max. Working Press.	276 psi (19 BAR)
Max. Suction Press.	87 psi (6 BAR)
Max. Test Press.	413.25 psi (28.5 BAR)
Max. Op. Speed	2200 RPM
Normal Op. Speed	2000 RPM
Min. Op. Speed	1400 RPM

Pump Curve

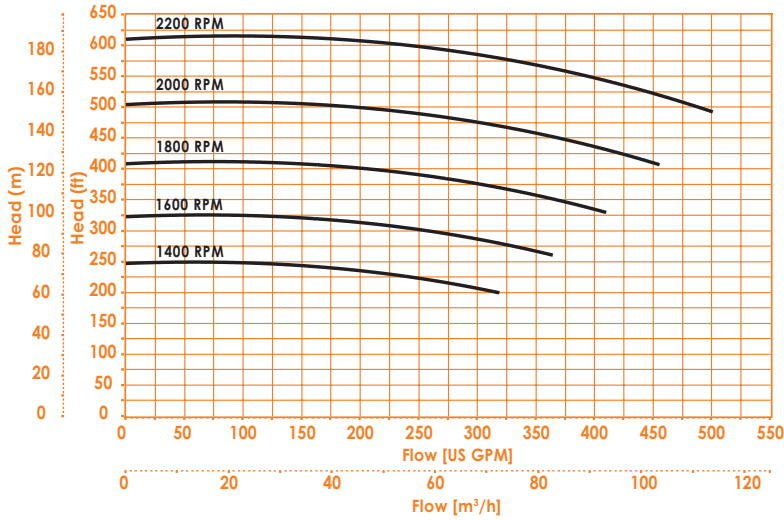

Materials

Pump Casing/ Separation Tank	Cast steel
Impeller	Cast steel, hardened to Brinnell 341 HB
Wearplates	High chrome cast iron hardened to Brinnell 625 HB
Mechanical Seal	Solid silicon carbide

Performance Table

Diesel Set - JD6068T, 144 HP (107 kW) @ 2200 RPM
 Impeller Diameter: 18" (465 mm)

Total Suction Head - Feet	Total Delivery Head - Feet			
	500	525	560	575
10	484	420	350	286
15	462	395	330	264
20	440	375	300	240

Performance data listed in table and curves based on water test at sea level and 68°F (20°C). Maximum flows may require larger diameter pipes.

Drawings

Skid-mounted John Deere 6068T engine
 Dry weight - 6100 lbs. (2769 kg)

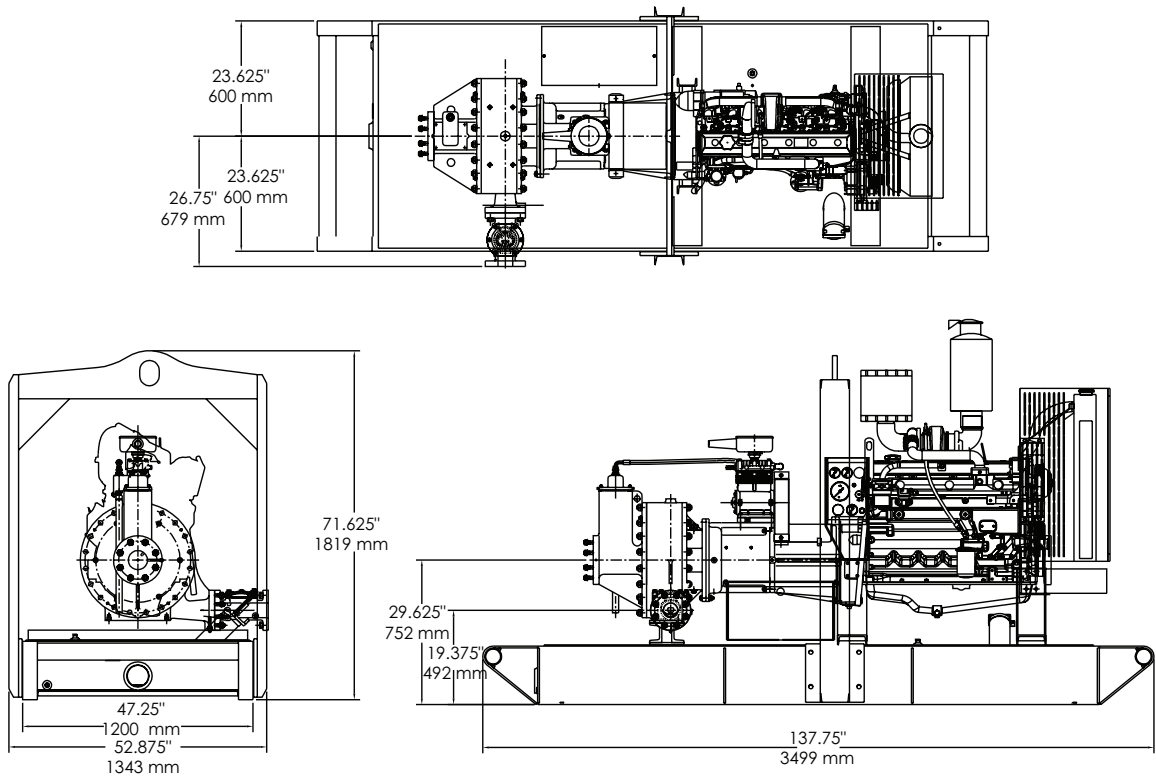

Home Office:
 Godwin Pumps of America, Inc.
 One Floodgate Road
 Bridgeport, NJ 08014 USA
 (856) 467-3636 • Fax: (856) 467-4841
 Email: sales@godwinpumps.com
 www.godwinpumps.com

