

Godwin HS80HH Heïdra Pump

The Godwin HS80HH hydraulic submersible pump is a compact self-contained pumping unit featuring a diesel-driven power pack and 3" (75 mm) submersible hydraulic top-discharging pump. The HS80HH offers improved performance and operating efficiencies that cannot be matched by standard electrical submersible models. With variable speed diesel engine power, the Heïdra HS80HH can meet a variety of flow and head requirements up to 450 GPM (28.4 l/s) and 325' (99 m) of total dynamic head with a simple throttle adjustment. Add the ability to pass solids to 1" (25 mm) in diameter, dry running capabilities, a cast chromium steel impeller, and you have a rugged dewatering/solids-handling, self-contained hydraulic submersible pump ready to go anywhere.



Features

- Rugged construction featuring cast iron pumping chamber and cast chromium steel impeller.
- The pump has independent bearings from the hydraulic gear motor, so pump loads do not affect gear motor performance.
- Mechanical seal in its own clean oil bath allows for indefinite dry-running. Seal faces are solid silicone carbide.
- Standard impeller is designed for general pumping, slurries and sludges.
- Gear motor connections are standard two-bolt SAE flange.
- For ease-of-maintenance, the gear motor has a "plug-in" connection to allow for quick changeover when required.

Specifications

Pipe Connections	3" (75 mm) 125# Flange Discharge
Max. Flow	450 GPM (28.4 l/sec.)
Max. Head	325' (99 m)
Solids Handling	1" (25 mm)
Impeller Diameter	12.8" (325 mm)
Max. Working Press.	155 PSI (10.7 BAR)
Max. Casing Press.	232 PSI (16.0 BAR)
Max. Op. Speed	2,400 RPM
Max. Op. Temp.	+230°F (110°C)
Hydraulic Output	32 GAL (121 l)
Hydraulic Capacity	40 GAL (151 l)
Fuel Tank Capacity	60 GAL* (227 l)
Fuel Consumption @ 2200 RPM (Full Load)	3.8 GPH (14.5 l/h)

* GP60 Trailer standard equipment

Pump Curve

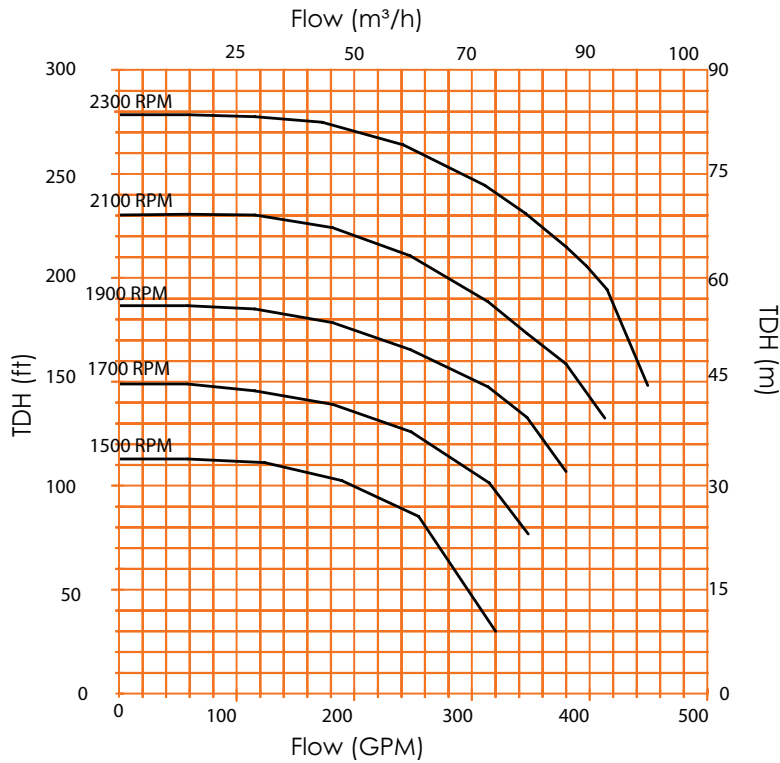

Materials

Parts	Material Type
Casing	Cast iron
Front and Rear Wearplates	Cast iron
Shaft	1-1/2% Ni/CR steel
Impeller	Cast CR Steel, 341 BN hardness
Bearing and Seal Housing	Cast Iron
Mechanical Seal	Double mechanical seal in oil bath with solid silicone carbide faces
Lifting Bracket	Fabricated mild steel tube and plate

Performance Table

Diesel Set : JD 4045T280
 Max Power Output: 71 HP (53 kw) @ 2400 RPM
 Impeller Diameter: 12.8" (325 mm)

GPM	400	300	200	100
Feet	200	250	270	278
PSI	86.5	108	116.9	120.3

Performance data listed in table and curves based on water tests at sea level and 68°F (20°C). Maximum flows may require larger diameter pipes.

Drawings

HS150MR hydraulic powerpack and HS80HH pumpend.

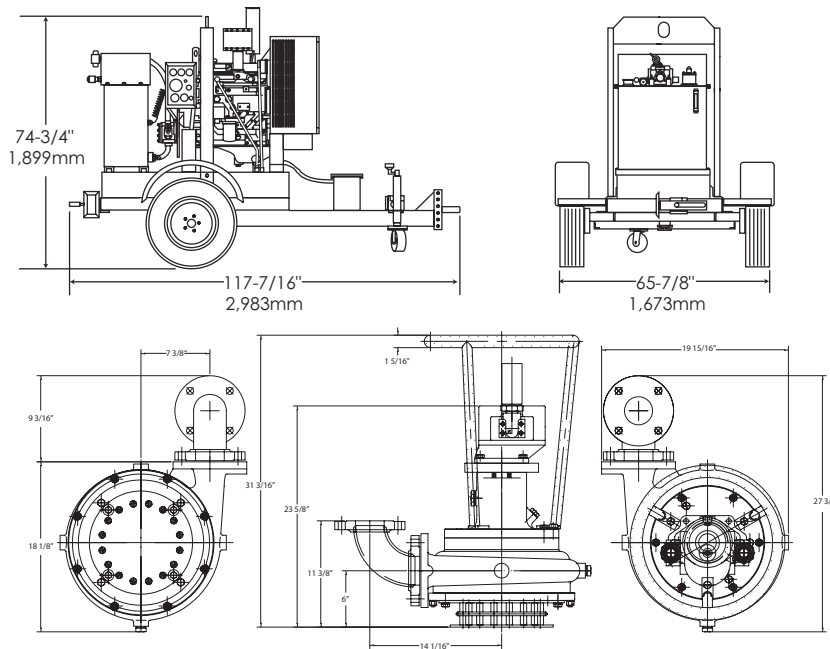

Home Office:
 Godwin Pumps of America, Inc.
 84 Floodgate Road
 Bridgeport, NJ 08014 USA
 (856) 467-3636 • Fax: (856) 467-4841
 sales@godwinpumps.com
 www.godwinpumps.com

